

ADD

***"Патентная защита
оригинальных программных
разработок"***

SoftPatent

Михаил Радченко

Зачем компании патенты?

- Единственный инструмент защиты R&D
- Инструмент цивилизованной продажи R&D
- Единственный способ продать R&D задорого
- РФ: Инструмент финансового управления
- РФ: Инструмент защиты бизнеса от рейдеров

Как выглядят soft-патенты

Google

«Advertising based on environmental conditions»

«Реклама основанная на условиях окружающей среды»

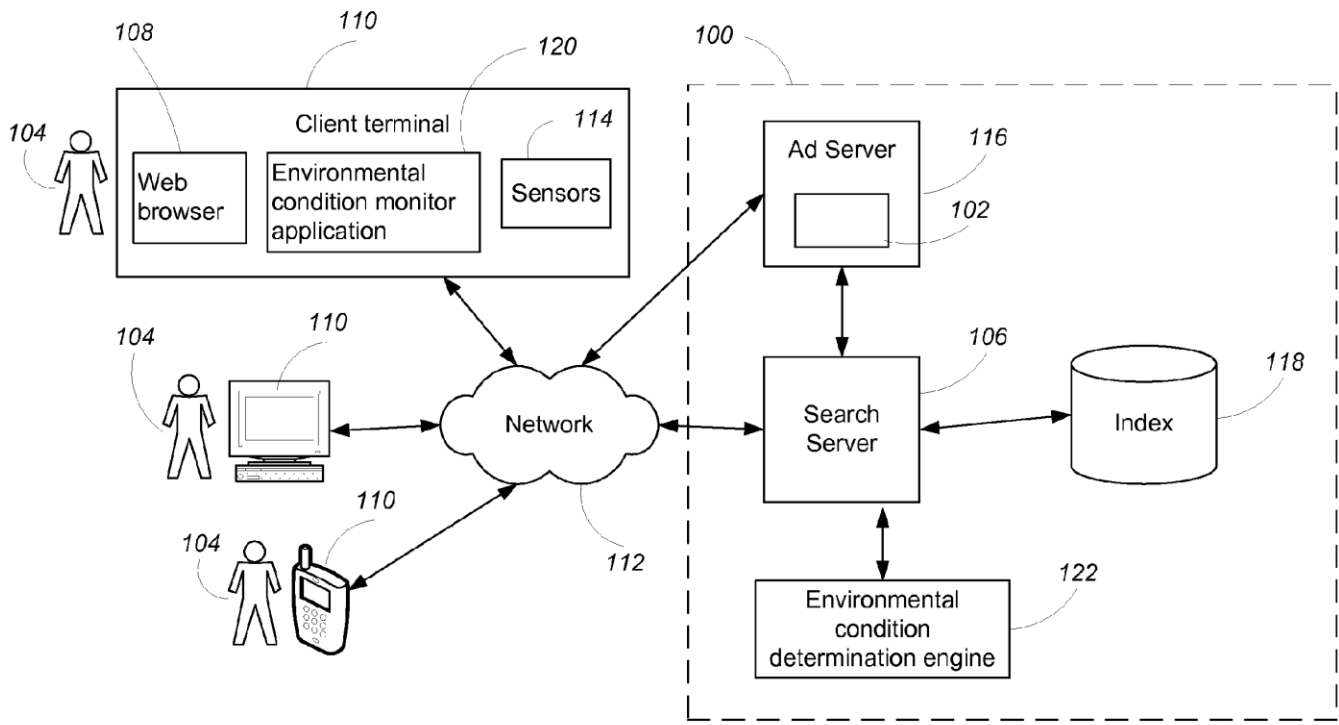

FIG. 1

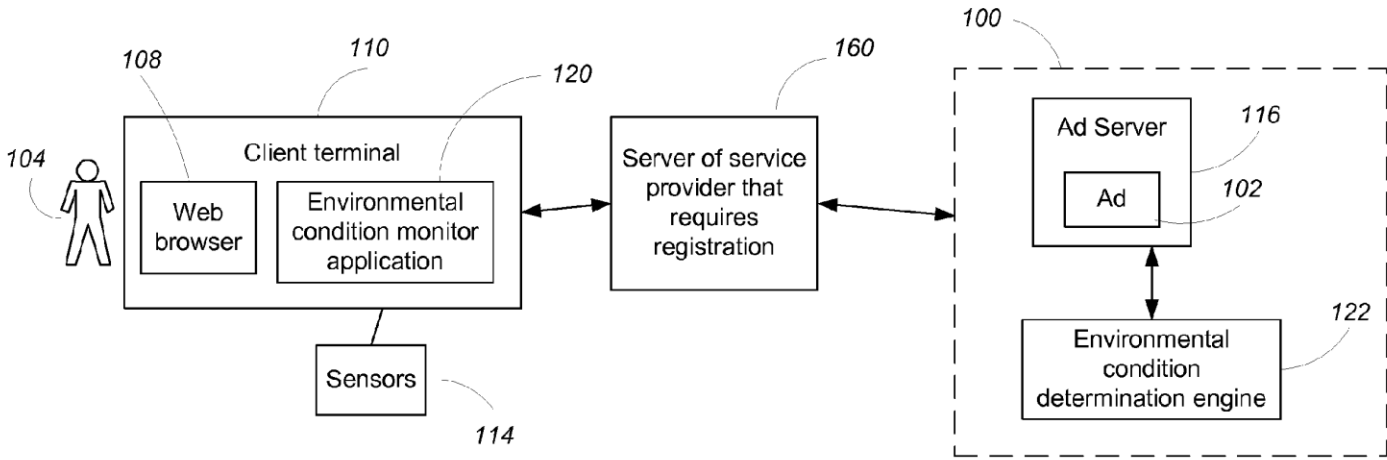

FIG. 2

Google

«Posting questions from search queries»

«Отправка вопросов из поисковых запросов»

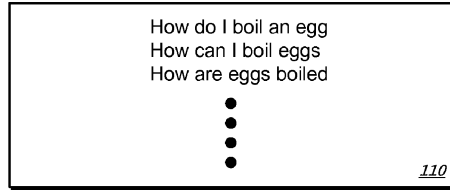

FIG. 2A

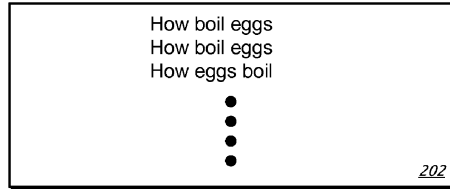

FIG. 2B

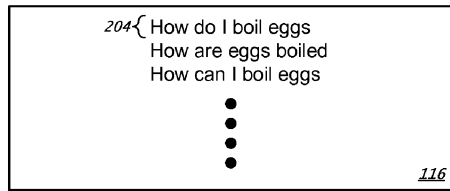

FIG. 2C

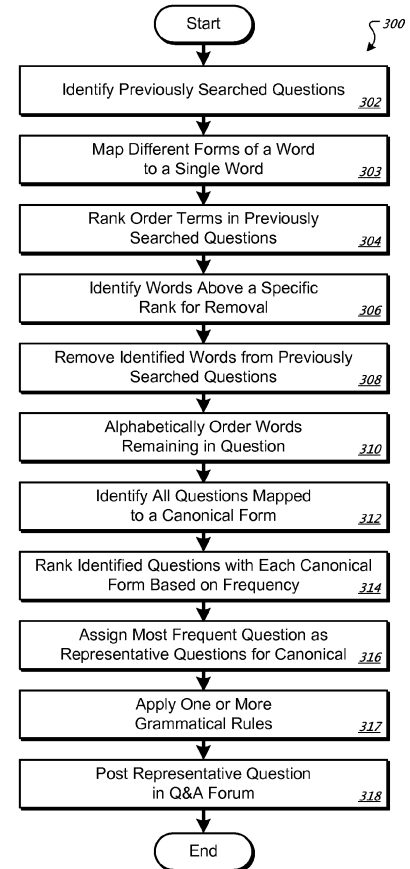

FIG. 3

Google

«Archive of text captures from rendered documents »

«Архивирование текста распознаваемых документов»

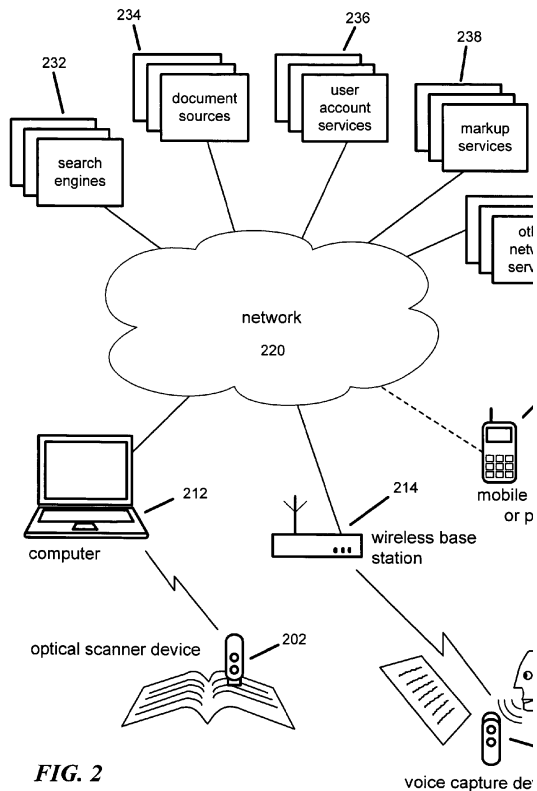

FIG. 2

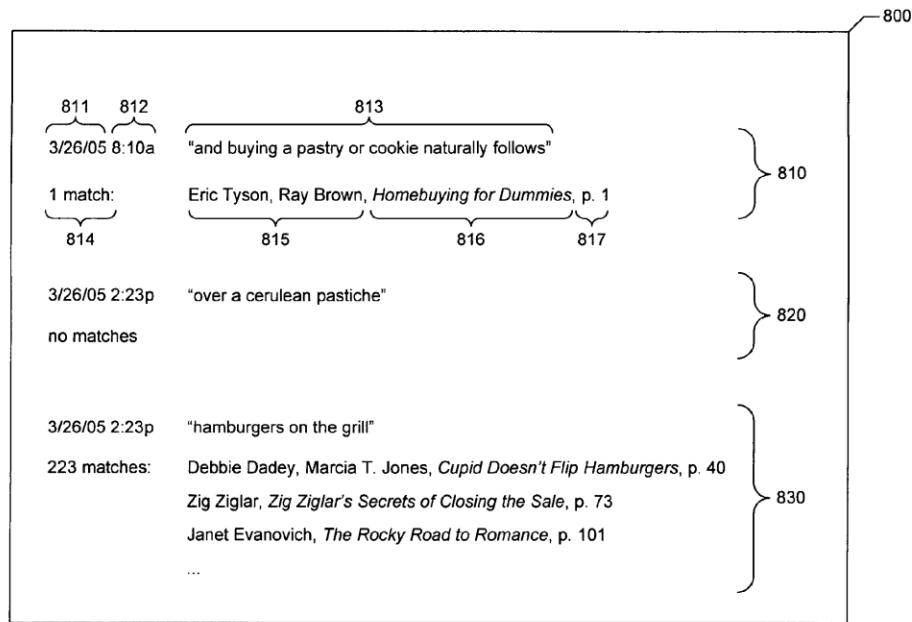
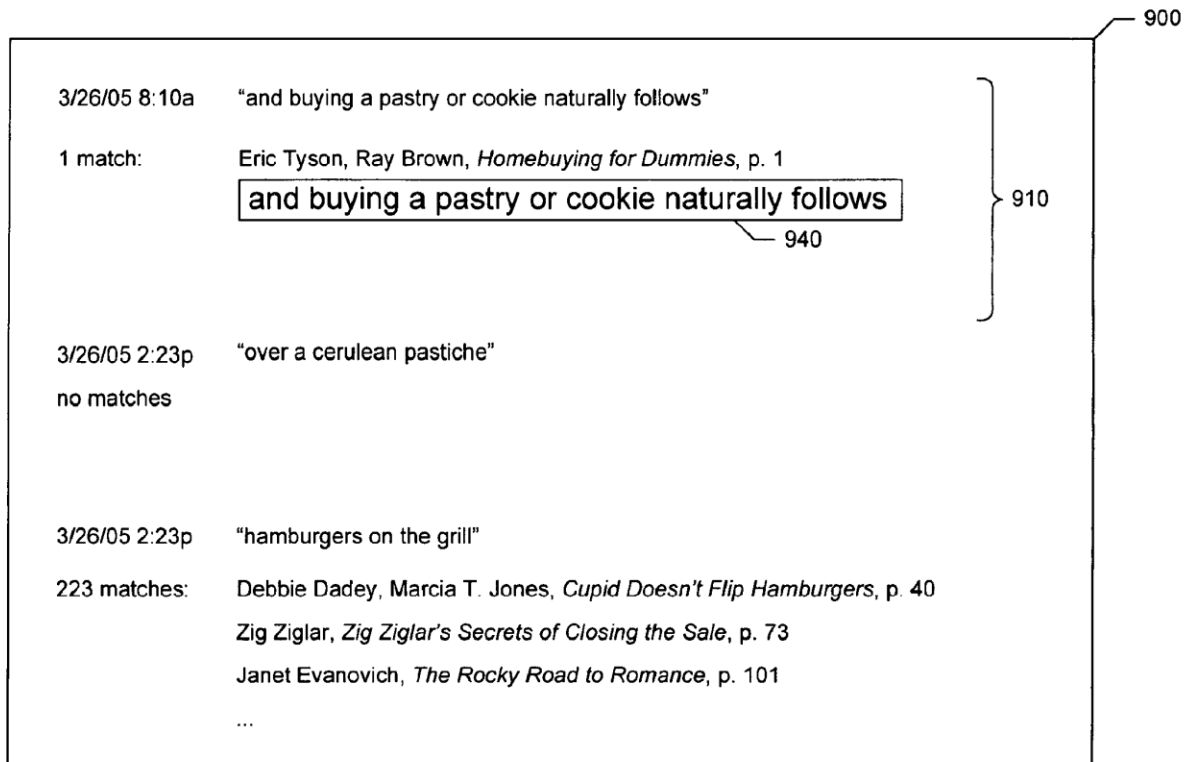

FIG. 8

**FIG. 9**

Google

«Governing the serving of advertisements based on a cost target»

«Управление показом рекламы на основе цены»

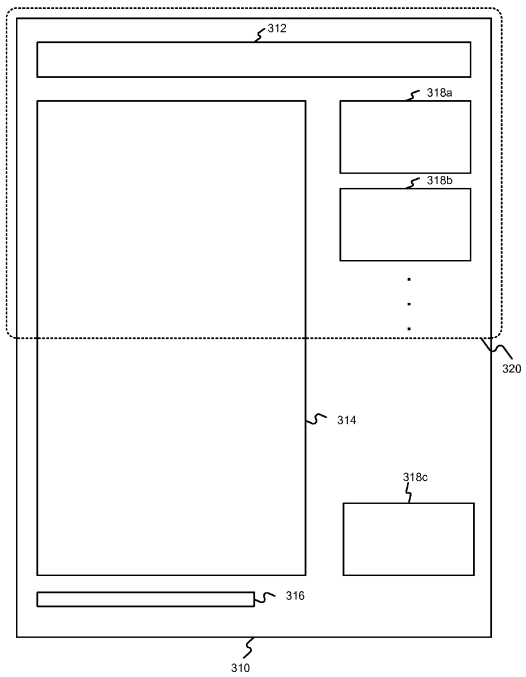

FIGURE 3

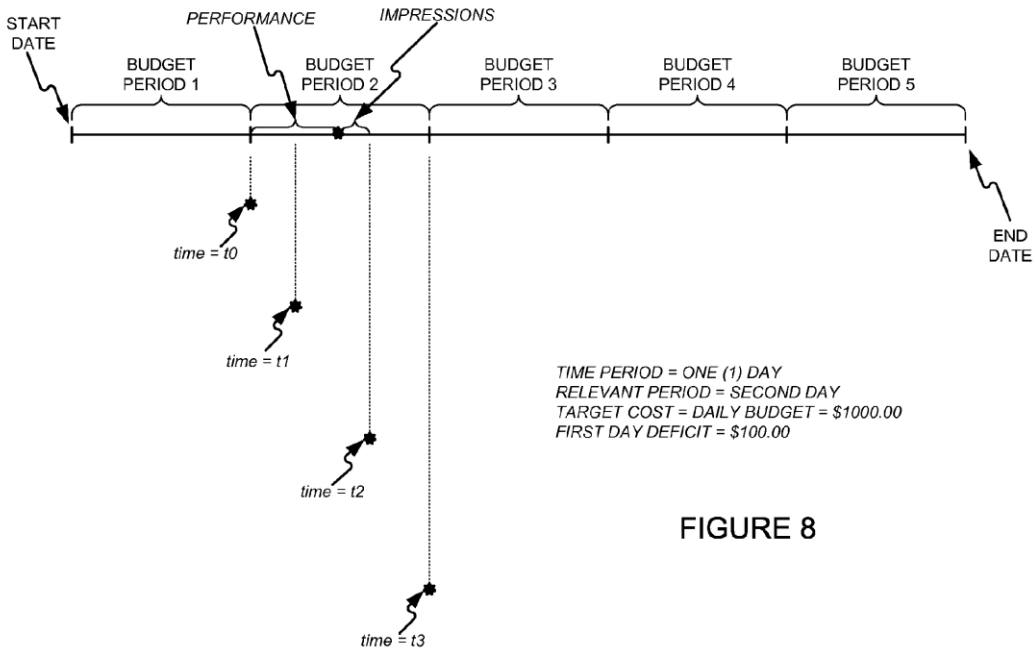
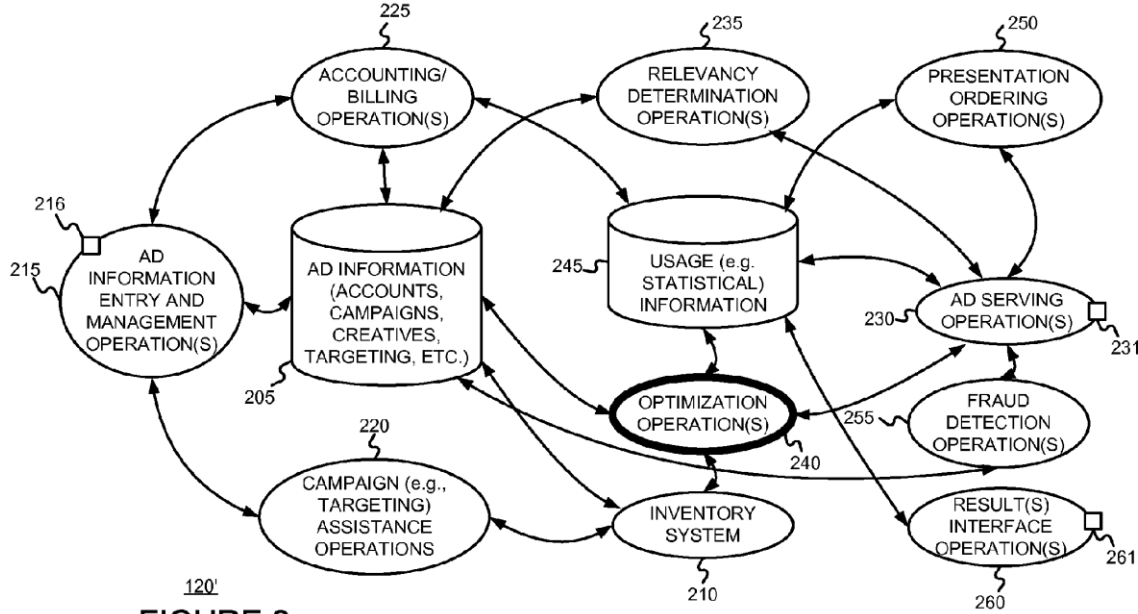
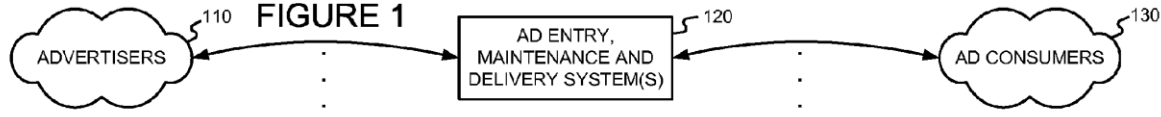

FIGURE 8



Google

«Geographic and keyword context in embedded applications »

«Географический и словарный контекст во вложенных приложениях»

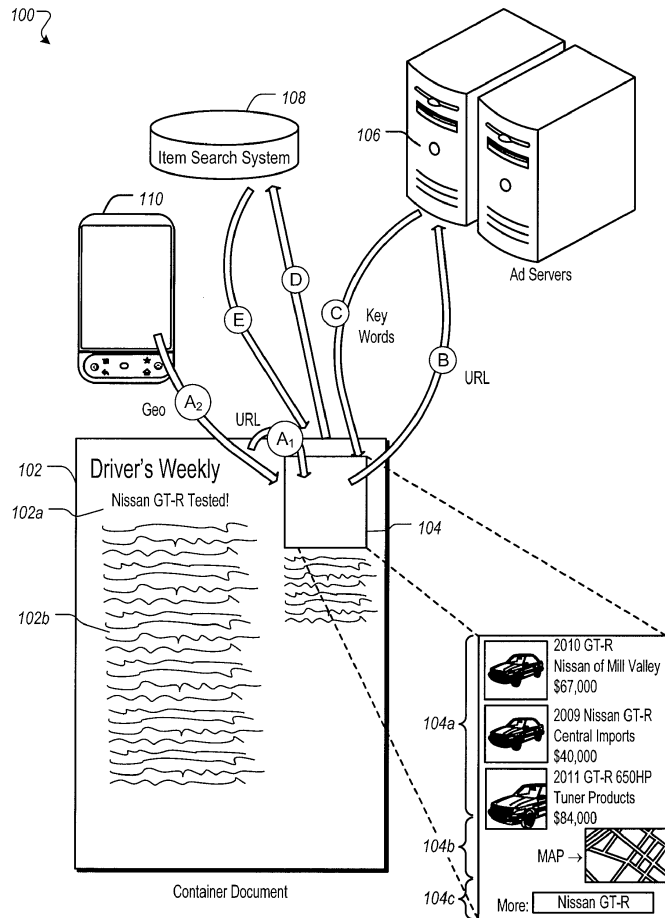

FIG. 1

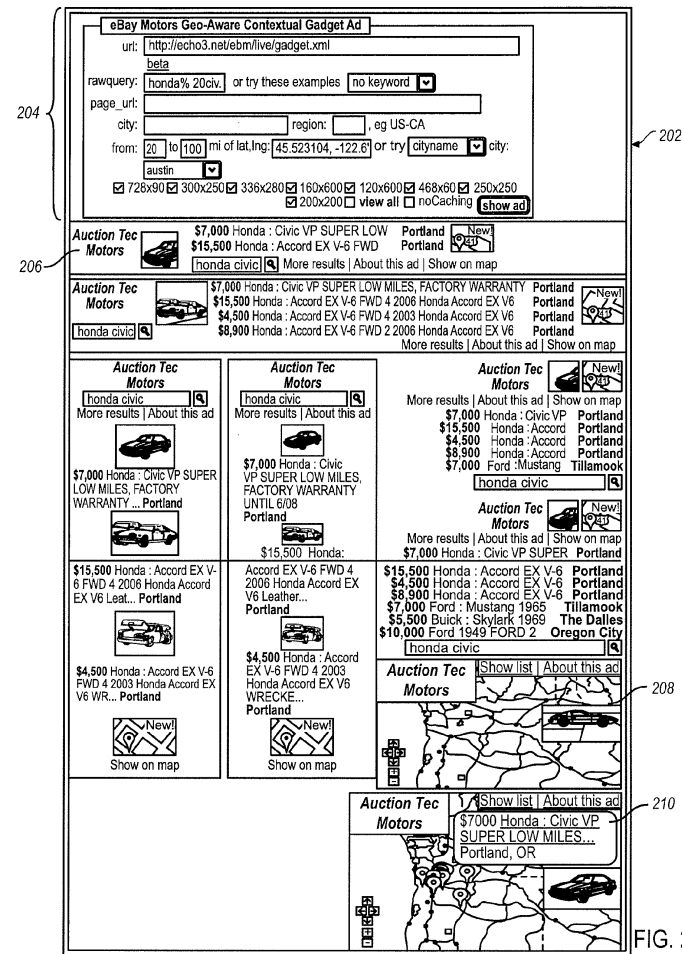

FIG. 2

Google

«User interface visualizations»

«Пользовательский интерфейс»

FIG. 1
(Prior Art)

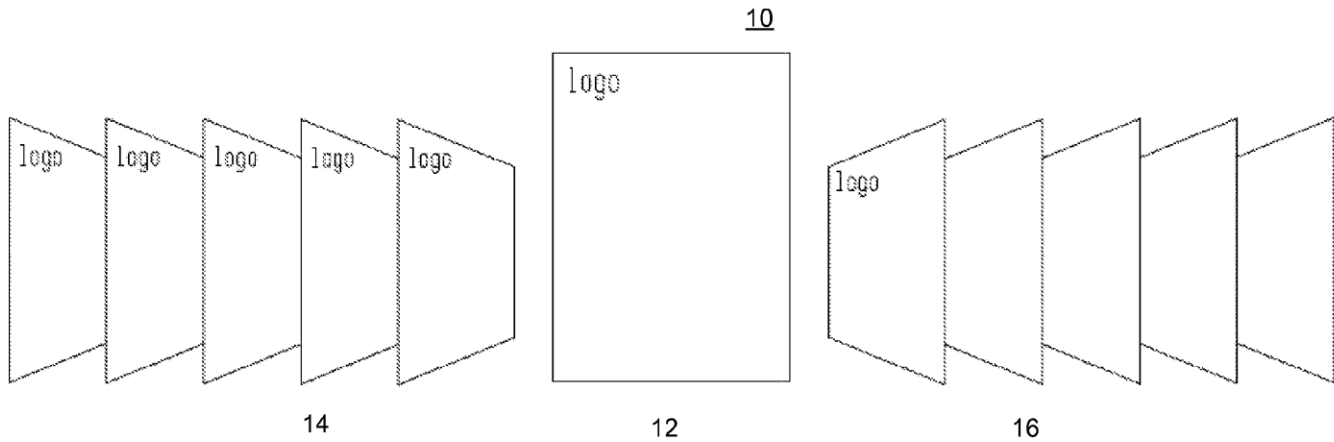

FIG. 3C

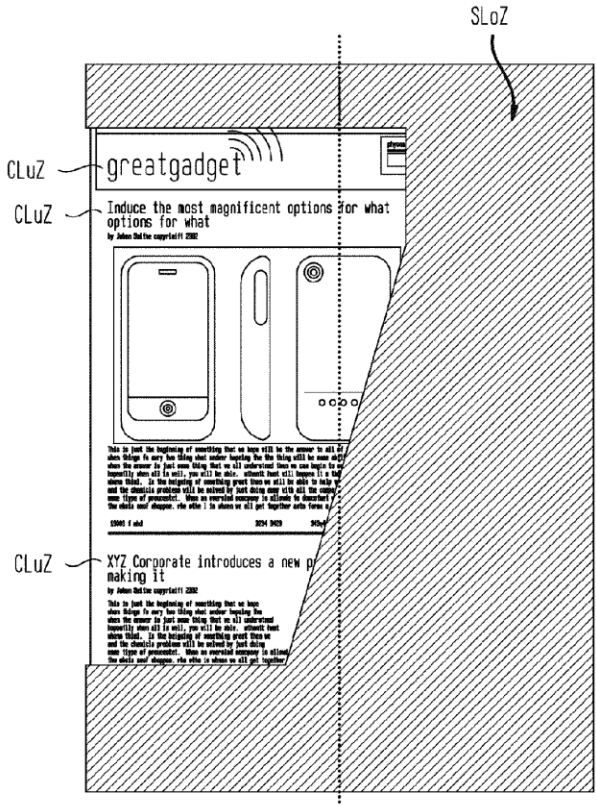
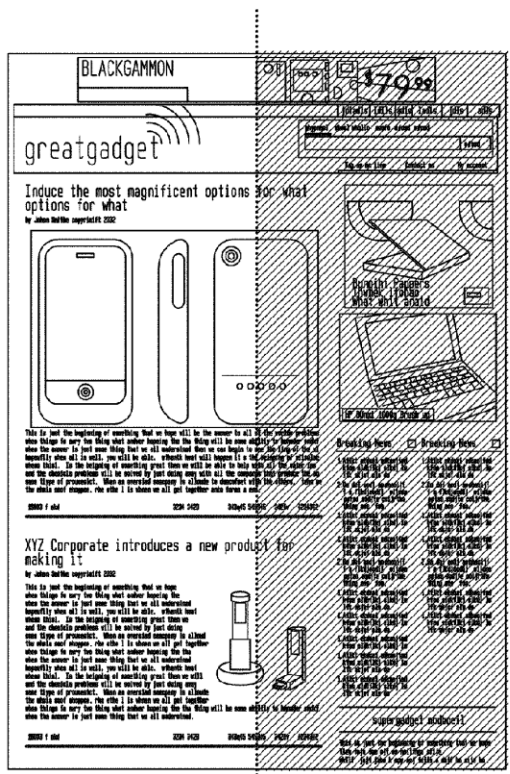
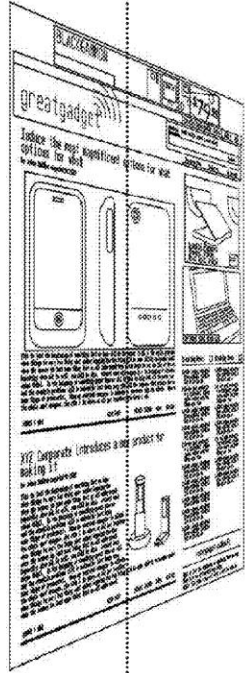

FIG. 3D



DARKEN SLoZ

FIG. 3E



TILT/TURN
CLUZ FORWARD,
SLUZ BACK

FIG. 3F

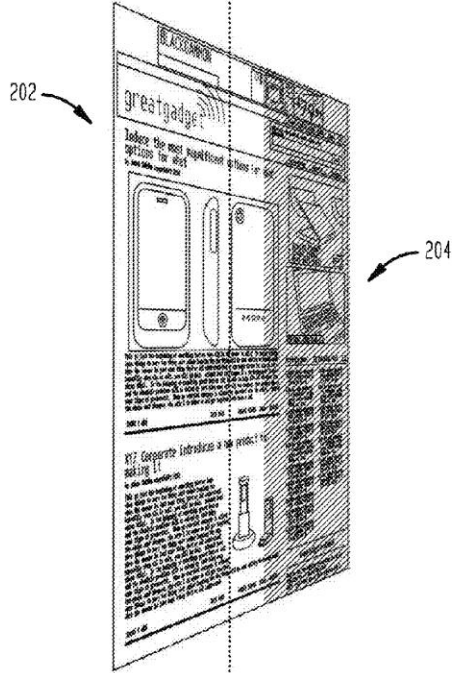

DARKENED/TILTED

Facebook

«Display panel of a programmed computer system with a graphical user interface »

«Интерфейс пользователя»

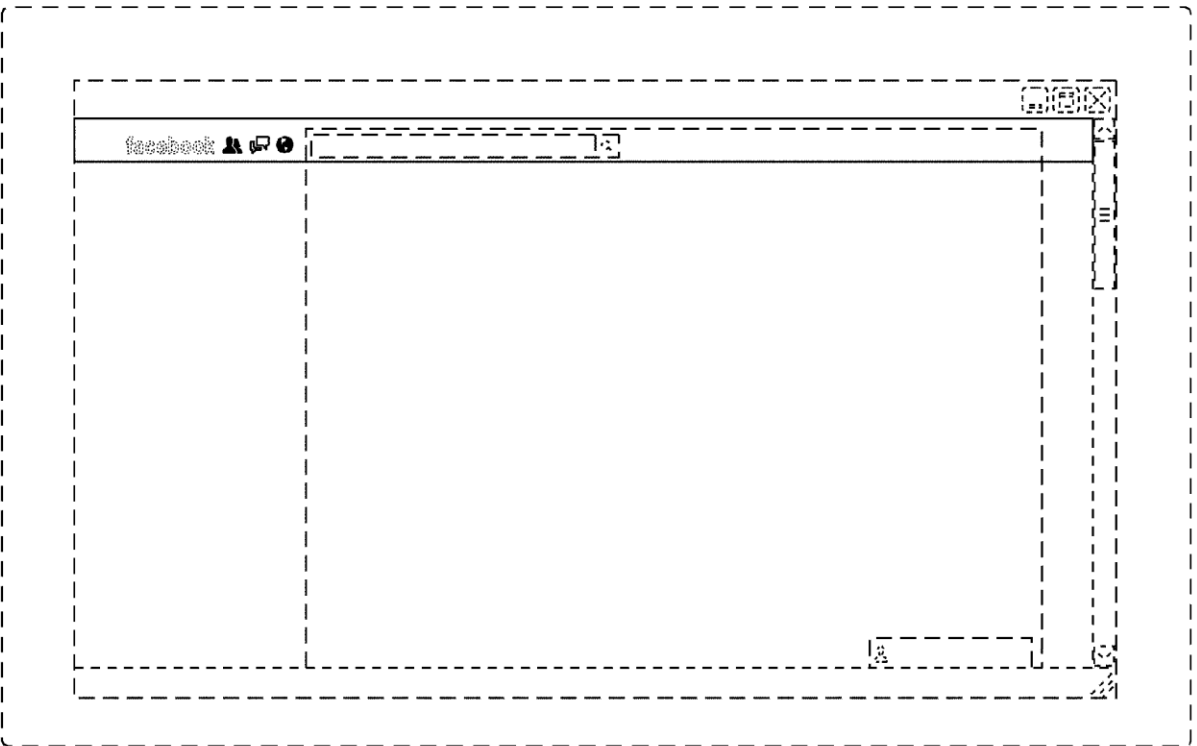

FIG. 1

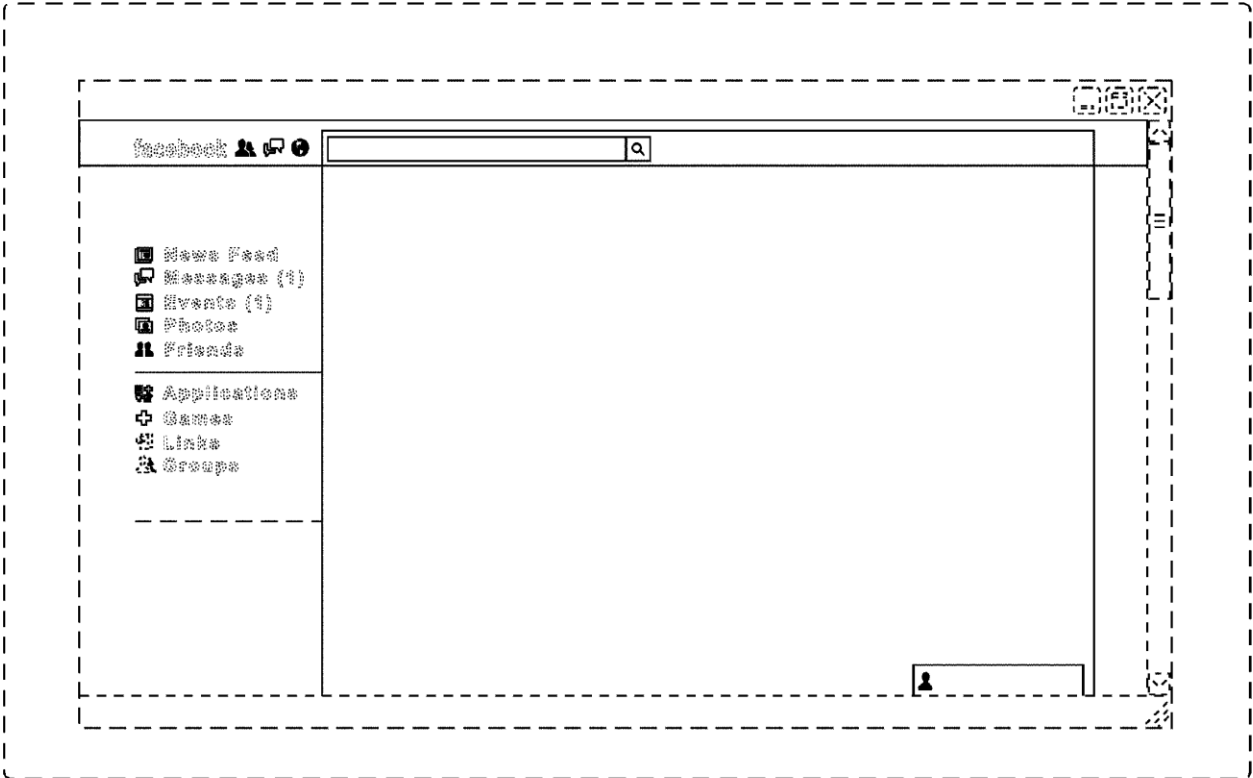

FIG. 1

Facebook

«Managing information about relationships in a social network via a social timeline »

«Управление информацией об отношениях в соцсети»

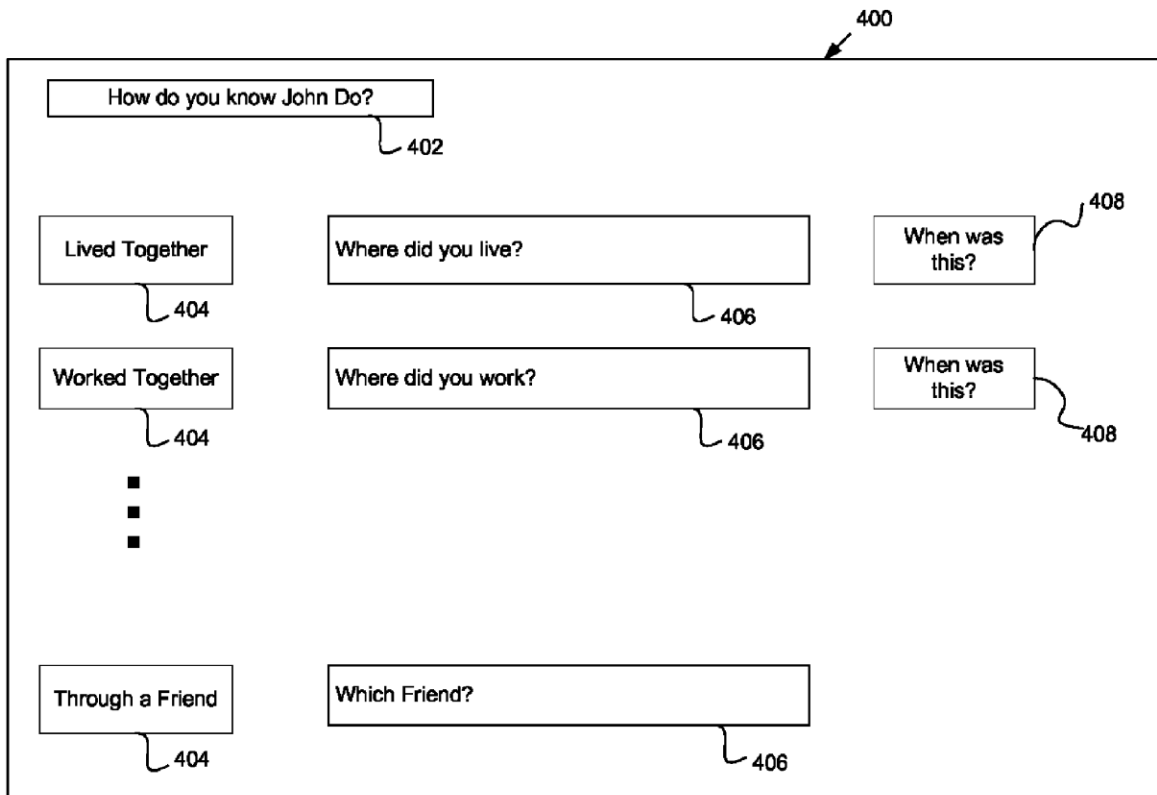

FIG. 4

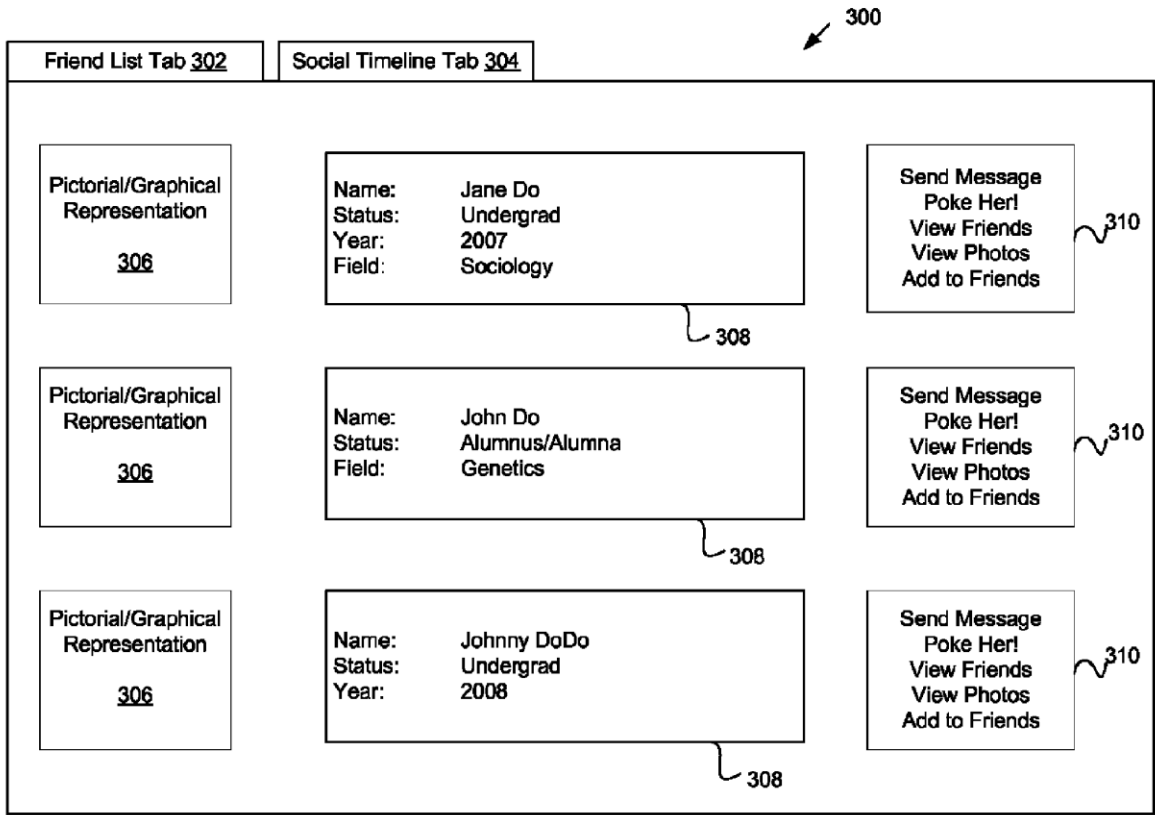

FIG. 3

Facebook

« Visual tags for search results generated from social network information »

«Генерация визуальных тегов для соцсети»

FIG. 1

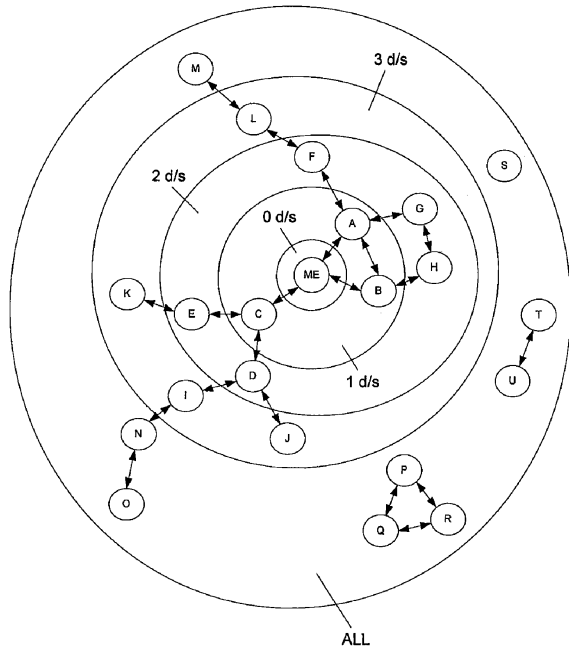
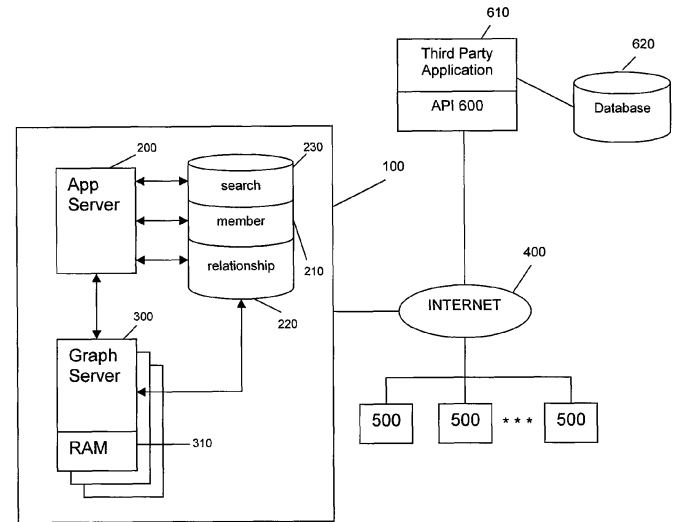

FIG. 2



Skype

«Synchronising contacts»

«Синхронизация контактов»

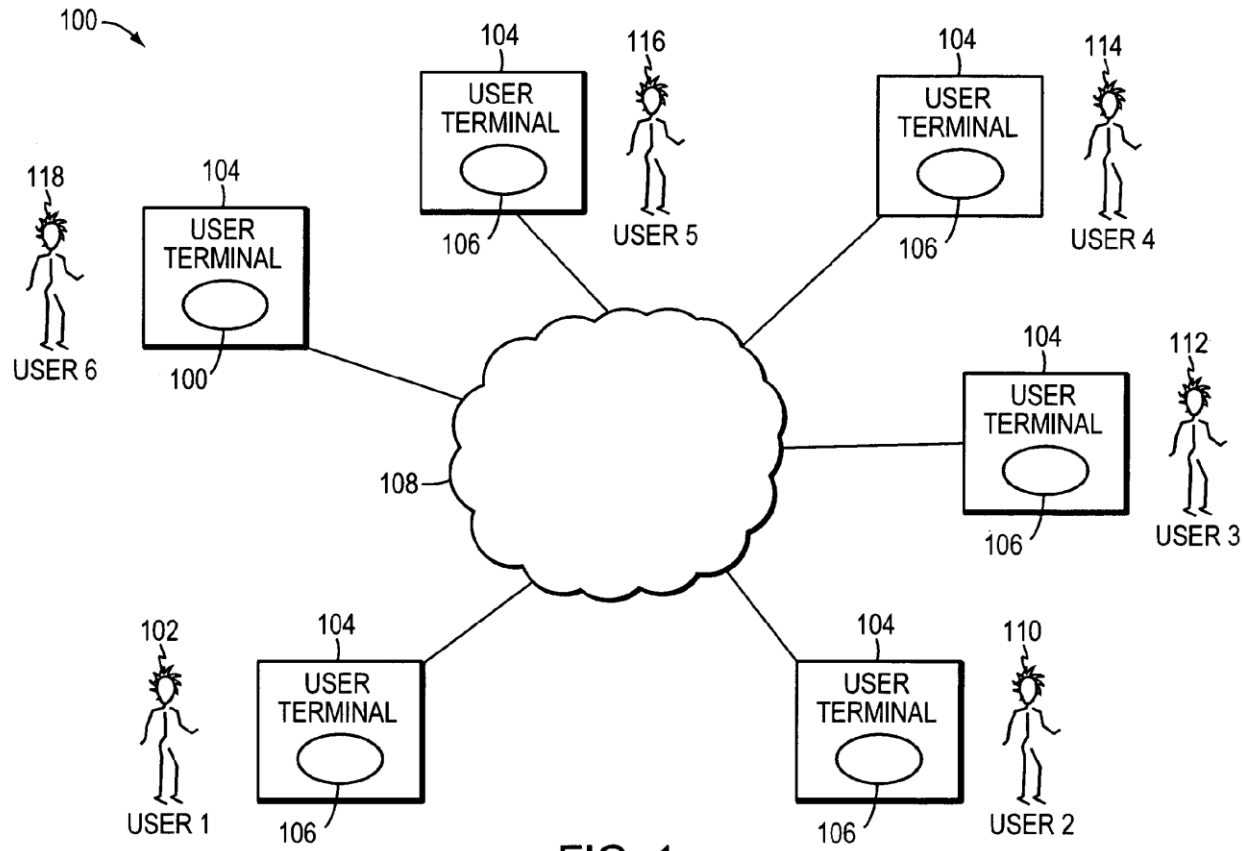
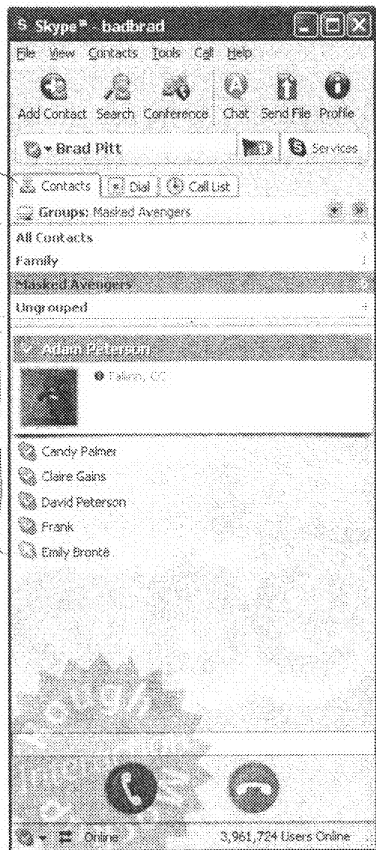

FIG. 1

200



202

204

208

206

FIGURE 2A

200

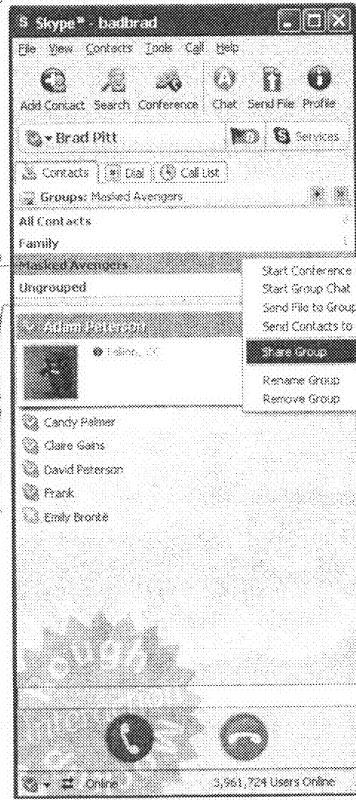

206

207

210

212

FIGURE 2B

Skype

«Dialling phone numbers »

«Набор номера»

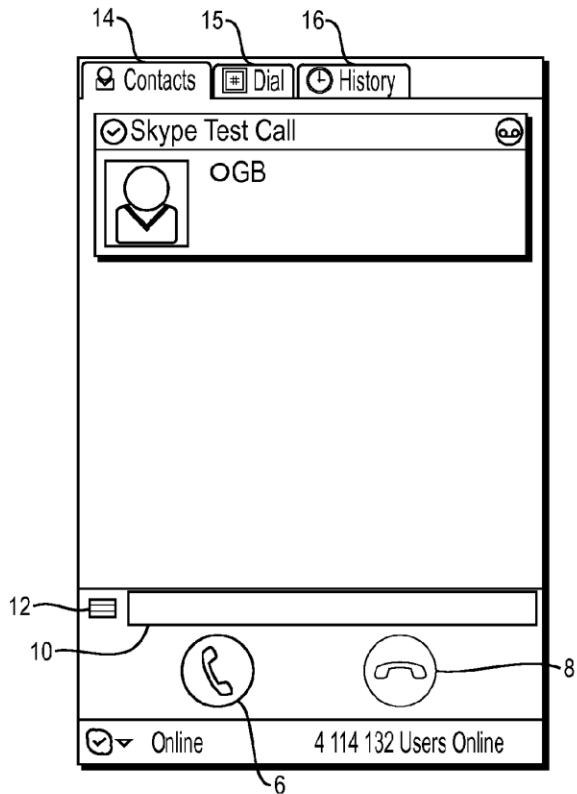

FIGURE 3

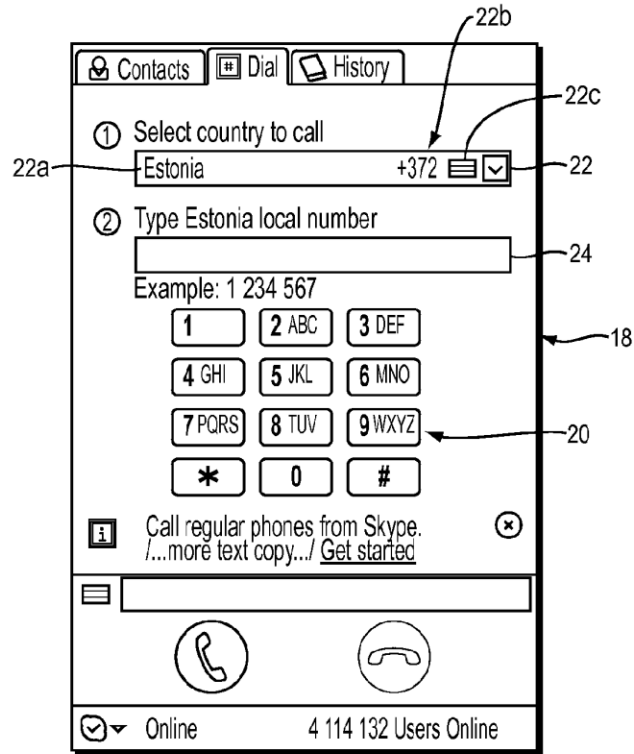

FIGURE 4

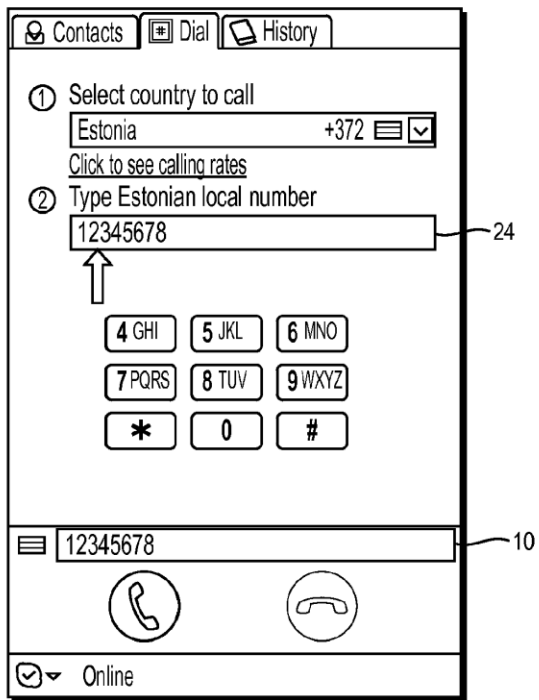

FIGURE 5

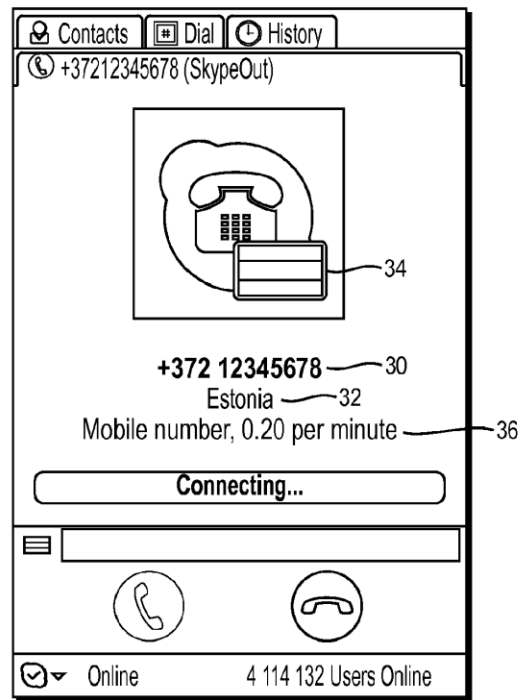
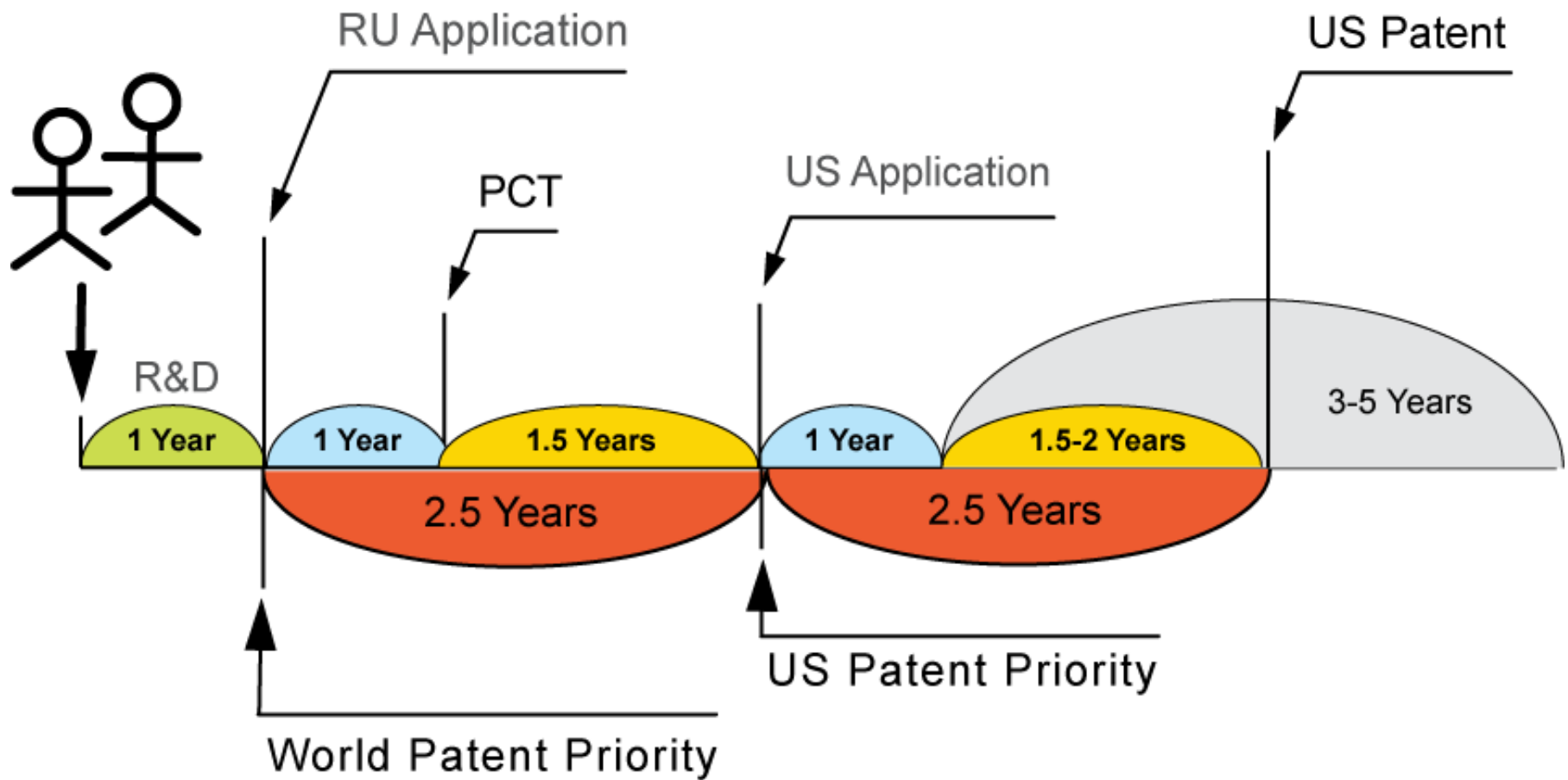

FIGURE 6

Сколько это стоит и занимает времени

USA / 1 патент / «долго»



USA / «быстро»

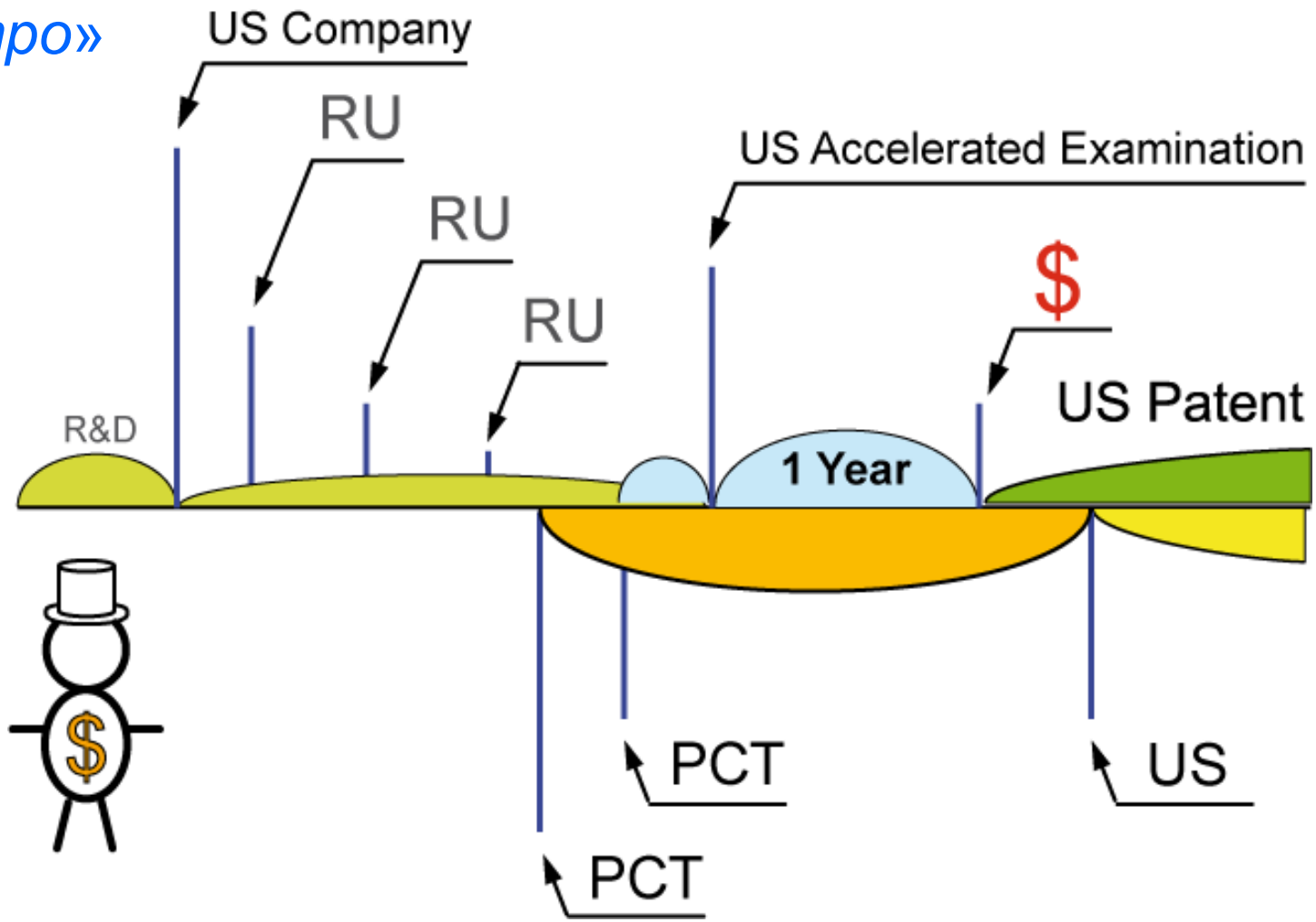

Процедура ЕРО (European Patent Office)

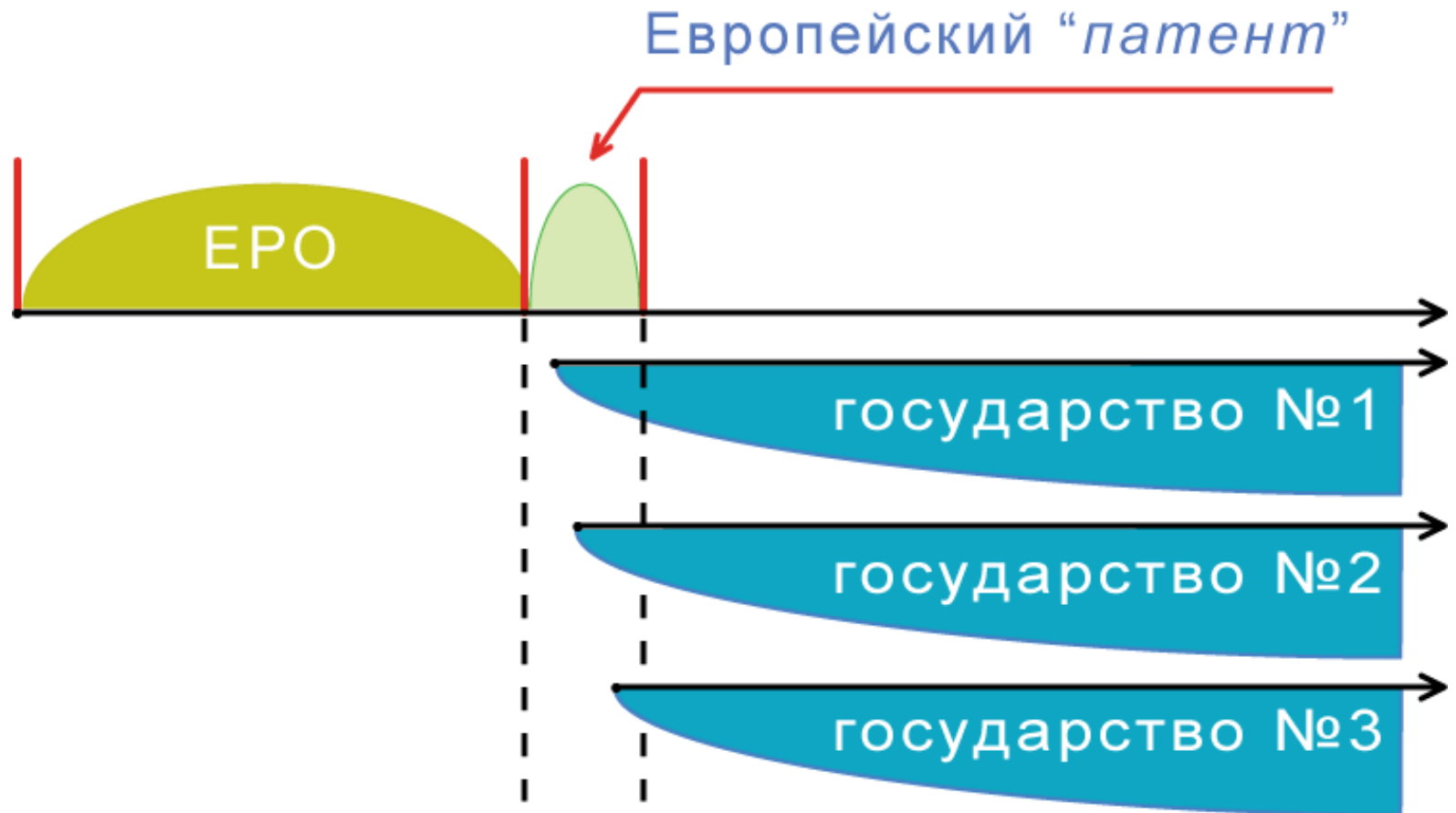

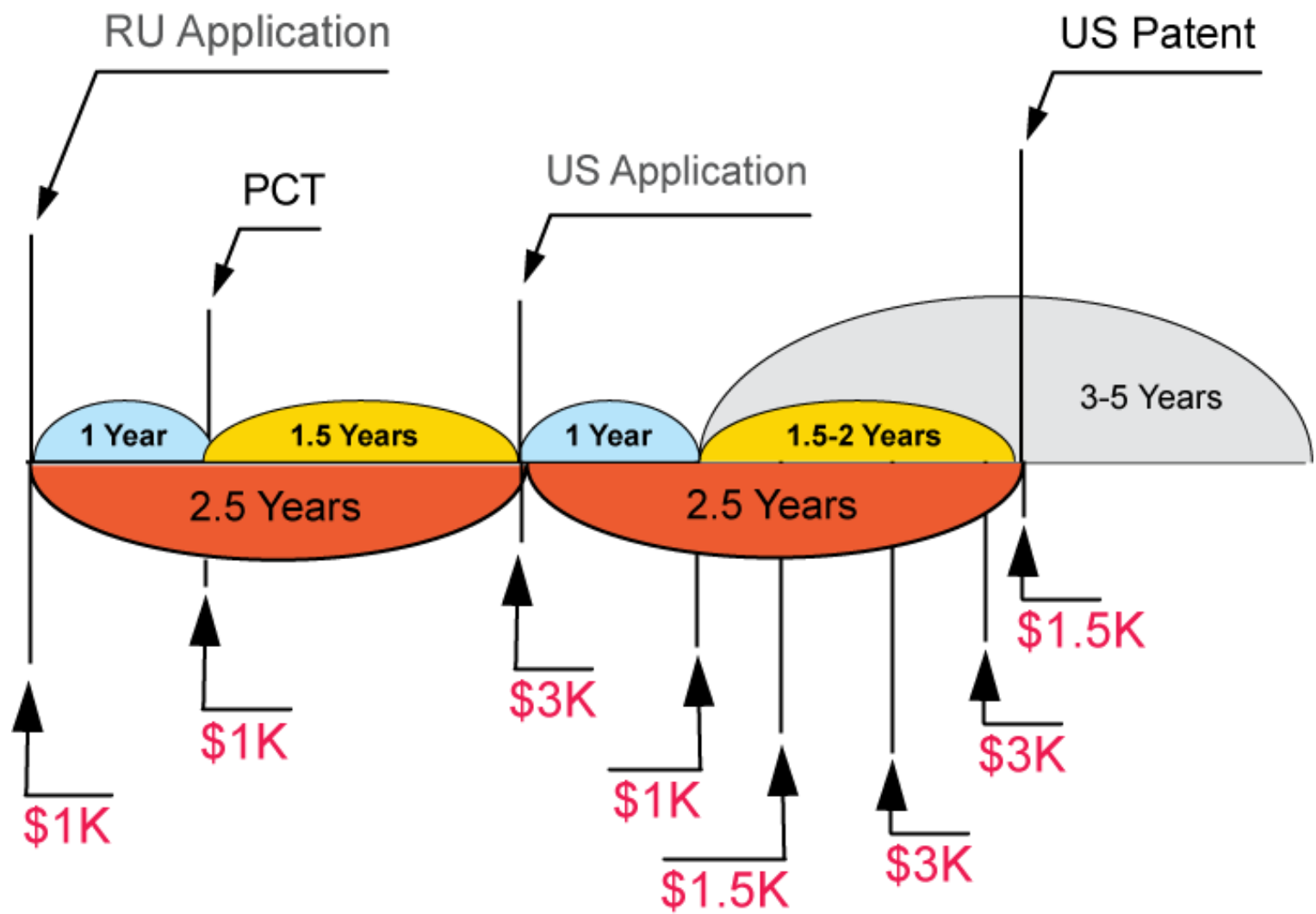

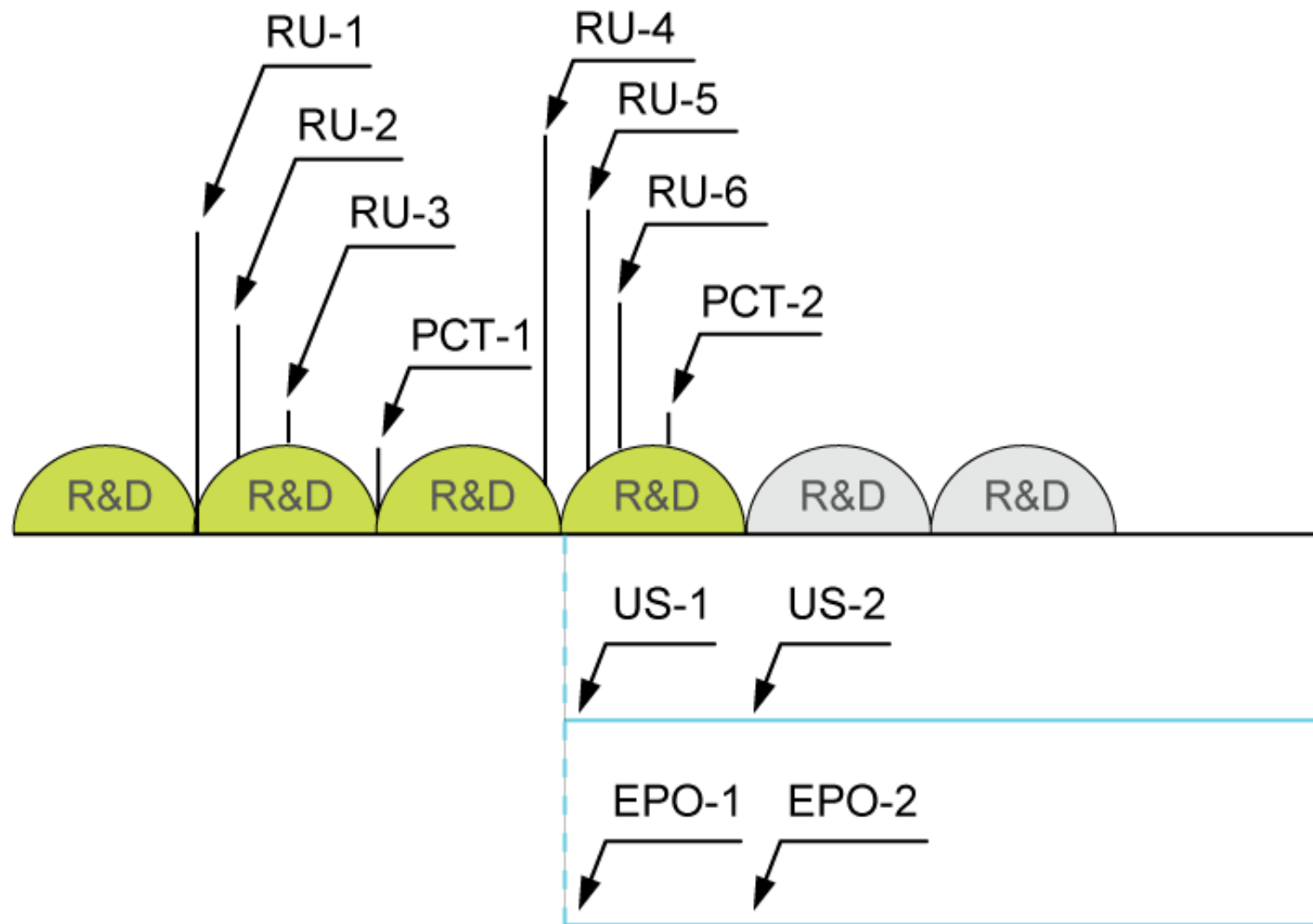

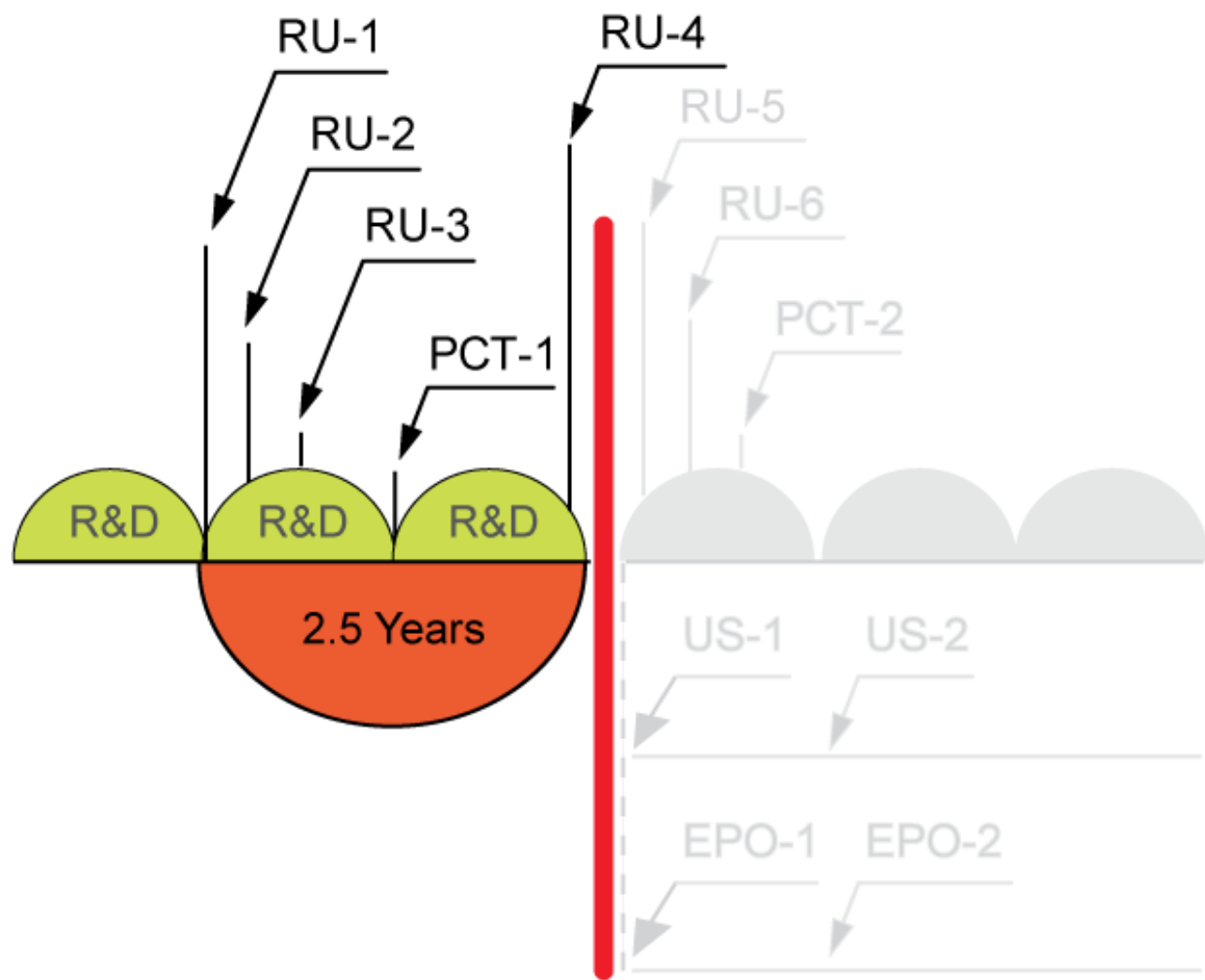



TechTunnel

SoftPatent

www.SoftPatent.ru

SoftPatent@ru.ru